

# Design of propeller turbines for pico hydro

**Robert Simpson & Arthur Williams**

This design guide is to be used alongside the calculation spreadsheets that can be downloaded from the Pico Hydro website ([www.picohydro.org.uk](http://www.picohydro.org.uk)). It is intended to be used by turbine design engineers and small manufacturers all over the world who want a low head turbine design suitable for rural electrification.

## Contents

1. Introduction	p 2
2. Turbine Design	p 3
3. Key Design Choices	p 5
4. Sizing	p 6
5. Runner Design	p 8
6. Casing Design	p13
7. Draft Tube Design	p14

## Version 1.1c, April 2011.

These guidelines are provided on an "Open Source" basis and may be copied and used by competent hydro engineers around the globe. The authors do not guarantee the performance of turbines produced using this guide, as this will be affected by manufacturing quality. Version 1 covers the design of turbines with constant thickness runner blades. It is published on the web site [www.picohydro.org.uk](http://www.picohydro.org.uk)

If you have further suggestions for corrections or improvements to this guide, please email: [arthur.williams@nottingham.ac.uk](mailto:arthur.williams@nottingham.ac.uk)

## 1. Introduction

Very small hydroelectric power schemes (pico hydro) with outputs of less than 5 kW can provide cost effective power to remote rural communities with water resources. Many sites have low heads (2 to 10m) but few have been developed because there has been a lack of appropriate turbine designs.

A project carried out by the authors in collaboration with Practical Action (assisted by funds from the Leverhulme Trust) provides a general design procedure for such turbines. Laboratory testing and computer modelling in the UK were used to develop these designs, backed up by field testing in Peru.

These guidelines are for use in conjunction with the design spreadsheet. In the guidelines are the steps required to carry out the hydraulic design of a turbine for a particular head and flow. They explain what information is required for the spreadsheet and give design recommendations for these turbines.

The pico propeller turbine uses a closed scroll casing that directs water onto the propeller. No guide vanes are needed, and the propeller blades are fixed. Tests show that guide vanes tend to cause energy losses in this type of turbine. The water exits through a conical draft tube.

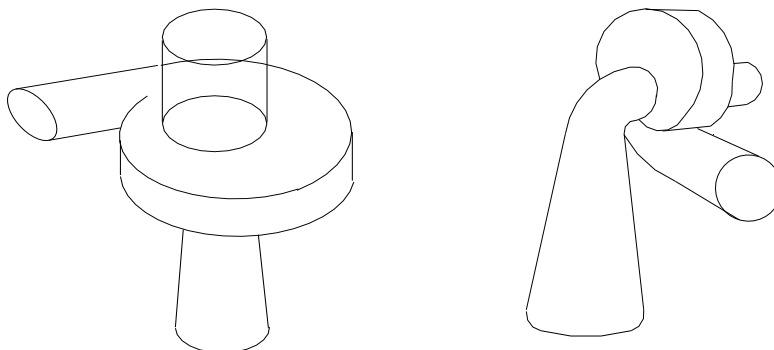

*Fig.1 Possible Turbine layouts (shown with a direct-drive generator)  
(a) vertical shaft (b) horizontal shaft*

Other layouts are possible for small axial-flow turbines but this particular layout was chosen for the following reasons:

- Standard bearings can be used, as the runner is “overhung”;
- It is possible to have a direct drive to the generator, without need for a long shaft;
- The design can be used for a wide range of heads (without likelihood of cavitation);
- The turbine can be manufactured using basic mechanical workshop equipment.

## 2.0 Turbine Design Spreadsheet

The design procedure follows a series of logical steps. The calculations for each step have been put into the spreadsheet. The flow chart on page 3 outlines the stages in the design procedure. Starting from the site data, the turbine speed should be chosen to give a *specific speed* which fits with the propeller turbine range.

The design starts from the runner and then calculates the dimensions of the scroll casing to give the correct swirl velocity at runner inlet. The dimensions of the runner may need to be adjusted through several iterations to avoid large twist in the blades or reverse angles at the hub, which would make the runner blades difficult to manufacture accurately. Choice of materials and manufacturing methods are left to the knowledge of the designer.

## 2.1 Turbine Design Parameters

The key design parameters for a turbine are head ( $H$ ), volume flow, or discharge ( $Q$ ) and rotational speed ( $N$ ). These values can be put into the spreadsheet "Sizing" page. From these three parameters, a "dimensionless shape number" or "specific speed" can be determined. This number gives an indication of the geometry of the turbine and it is the starting point for detailed design.

There are many different forms of the specific speed. For this design procedure we use the following equation:

$$n_q = \frac{N\sqrt{Q}}{H^{0.75}}$$

where  $N$  is in rev/min,  $Q$  in  $\text{m}^3/\text{s}$  and  $H$  in m.

So, the starting point for the turbine design is to decide the values of  $Q$ ,  $N$  and  $H$ . One of the key findings of the authors was that measuring the available flow rate accurately is critical for effective design of the turbine, as there is no adjustment for flow variation when the turbine has been made. If the actual flow available is lower than the turbine design flow,  $Q$ , the turbine will generate very little power.

The choice of the speed,  $N$ , depends on the speed of the generator and the type of drive used. Often it is possible to use a direct drive, with the turbine runner attached to the end of an extended generator shaft. On the other hand, using a single stage belt drive allows the possibility of changing the turbine operating speed. This gives more flexibility in the turbine design and in matching to site conditions.

*Fig.2 (on next page) Flow Chart for the Design Spreadsheet*

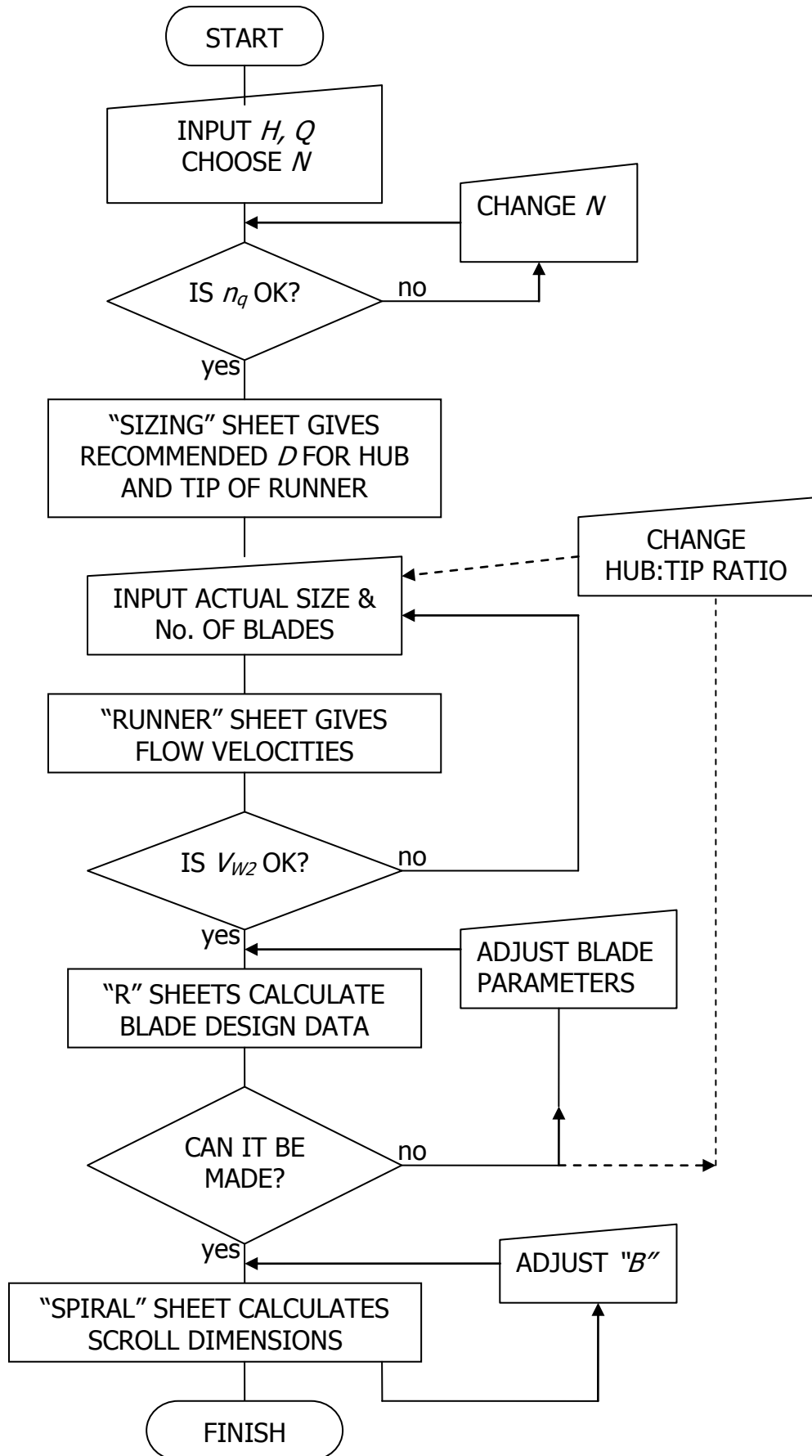

## 2.3 Specific Speed and Varying Flow

The expected range of specific speed values is  $70 < n_q < 300$ . If the specific speed is less than 70, then you should look at an alternative type of turbine – e.g. crossflow (Mitchell-Banki), pump as turbine or turgo.

You should avoid designing a turbine with a specific speed greater than 250 as this will tend to have a low efficiency. Where head is low and flow high, it might be a good idea to design for parallel turbines, each operating on part of the total flow. Otherwise it is necessary to choose a lower speed for the turbine, which will result in a large physical size. Two smaller turbines running at higher speed may be not much more costly than one large turbine. An example of this type of turbine selection is given in section 4.1. Two parallel turbines have greater flexibility of operation when flow rates vary.

If the turbine flow varies between two main seasons in the year, then it may be possible to design two different runners that can be changed over, one for higher flow and one for lower flow. Both runners can be designed to operate with good efficiency in the same casing, but additional care is needed in the design, as they will have different specific speeds. It is planned to give an example in a later version of this manual.

## 3.0 Key Design choices

There are some decisions about the turbine that the designer needs to make during the design process. For example, there are two options for the spiral casing design – a parallel sided casing or a tapered casing. For the runner blades there is a choice between aerofoil cross-section and constant thickness blades. There is also a choice to be made regarding the material for the runner.

### 3.1 Shaft Orientation

The choice between horizontal and vertical shaft (Fig. 1) will depend on the application and the designer's preference. This decision is important as it will affect the power house layout. A horizontal shaft layout of the turbine has the following advantages:

- ✓ Allows a mechanical load to be connected more easily;
- ✓ Easier to change rotors if the need arises;

A vertical shaft arrangement may reduce losses in the draft tube because it does not need a 90-degree bend. It may also have advantages if using a direct-drive generator:

- ✓ Any water leakage is likely to run away from the generator;
- ✓ There is less axial load on the extended shaft.

### 3.2 Scroll Casing Design

There is a significant difference in the flow pattern produced by a constant height spiral casing as compared with a tapered spiral design; this affects the matching of the scroll casing and the runner blade design. The advantage of the tapered casing is that it is easier to create a suitable flow angle into the runner and less material is used for the same size of turbine, making it slightly lighter to transport. However, for very low heads (below 3 - 4 m) the tapered scroll is not recommended because it creates a high velocity at the inlet to the runner, which causes a very low pressure to occur. This leads to two potential problems: i) the shaft seal tends to suck in air; ii) there may be low enough pressure for cavitation to occur. Both of these problems are serious as they lead to a reduction in turbine efficiency and may also cause damage to the turbine runner.

### 3.3 Blade Design

The choice of aerofoil blades or constant thickness blades relates to the manufacturing process. Tests on prototype turbines showed that good quality of manufacture of the blades is important to obtain high efficiency – each blade needs to match the design. Good surface finish also improves efficiency. However, achieving the required blade twist (the change of angle from hub to tip) is more important than having a complex blade profile.

Aerofoil blades would normally be made by casting individual blades that are then welded onto the hub. These could be of aluminium or bronze. Constant thickness blades would normally be used with a steel runner. They can be made out of sheet steel, cut, bent and twisted into shape and then welded onto the hub. When welding the blades, it is recommended to use a jig to hold each blade at the correct angle to the hub. It is important that the runner blades are evenly spaced around the runner and are each set at the same angle.

## 4. Guide to "Sizing" Sheet

The value of the tip velocity to the head velocity is a key parameter in the turbine sizing. The equation for this ratio is:

$$k_{ug} = \frac{r_{tip} \times \omega}{\sqrt{2gH}}$$

where  $r_{tip}$  is the blade tip radius, i.e.  $r_{tip} = D/2$  and  $\omega$  is the angular velocity of the turbine runner, in rad/s, i.e.  $\omega = 2\pi N/60$ . In the spreadsheet  $k_{ug}$  is calculated according to the specific speed, based on the graph shown below.

There are two other parameters shown on this graph, which are input by the designer in the "Sizing" sheet. These are the diameter ratio of runner hub:tip and the number of runner blades ( $Z$ ). The values on the graph are for guidance. The values for the number of blades have been modified because

for small turbines it is better to have fewer blades on the runner. This graph is adapted from a book by Willi Bohl<sup>1</sup> that is itself based on efficient Kaplan turbine designs.

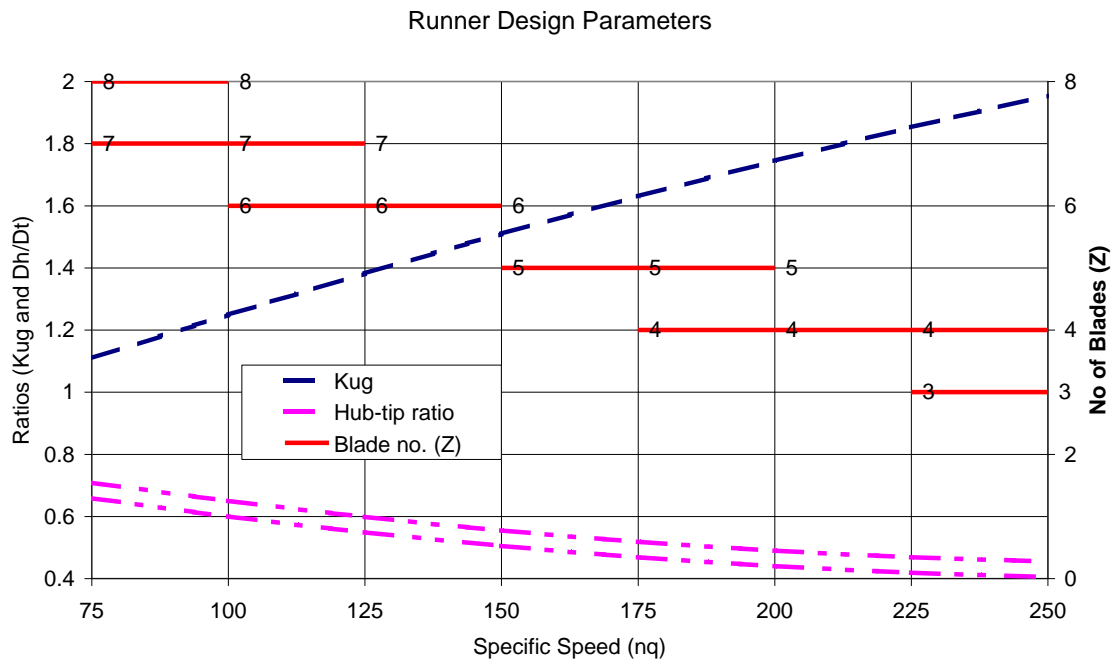

Fig.3 Design Parameters for "Sizing" sheet

When choosing the hub:tip ratio, remember that a smaller ratio will mean a relatively large twist needed in the blade. For ease of manufacture of small high specific speed turbines, it may be advisable to use an even larger value than indicated by the range on the graph.

#### 4.1 Example of Turbine Options

As an example of the options produced by the "Sizing" sheet, Table 1 gives the dimensions for turbines to fit a head of 2.5 m and total flow of 460 litre/s.

	1 turbine	2 (direct drive)	2 (belt drive)
Turbine Flow (l/s)	460	230	230
Speed (rpm)	720	1030	720
Specific Speed ( $n_q$ )	246	248	174
Runner dia. (mm)	360	250	300

To achieve the recommended  $n_q < 250$  either the flow is limited or the speed must be reduced. 1030 rpm has been chosen as it is suitable for direct drive of a standard 6-pole 50 Hz induction motor as generator. The detailed design in the example spreadsheet has been carried out for the middle option.

<sup>1</sup> W. Bohl, "Strömungsmaschinen", Vol.2, "Berechnung & Konstruktion", Vogel Buchverlag, 1991 (in German).

## 4.2 Hydraulic Efficiency

An estimate of the hydraulic efficiency is required for calculating the turbine dimensions. At the bottom of the sizing sheet there are two estimates of the hydraulic efficiency. These are based on statistical data on a large number of turbines, collated by Anderson<sup>2</sup>.

The upper figure shows the mean hydraulic efficiency for turbines with this flow rate. The lower figure takes into account the specific speed. It demonstrates the efficiency disadvantage of choosing a high specific speed machine. This value, or an estimate from elsewhere, can be input at the top of the spreadsheet.

## 5. Runner Design Guide

The process of designing the runner using *constant thickness* blades is outlined in the flowchart on the next page. This worksheet picks up data from the "Sizing" worksheet giving the basic dimensions of the runner. It calculates the shapes of the blades required when using constant thickness, circular arc blades. It is later intended to publish a similar sheet for designing profiled (aerofoil) blades.

According to basic theory, using the Euler equation:

$$g\eta_h H = u_1 v_{w1} - u_2 v_{w2}$$

where  $u$  is the peripheral speed of the runner (1 at inlet and 2 at outlet) and  $v_w$  is the tangential (or whirl) component of the water velocity. For an axial flow turbine  $u_1 = u_2$ . The axial flow velocity through the runner is calculated

from: 
$$v_a = \frac{Q}{\pi r_t^2 - r_h^2} = \frac{4Q}{\pi D_t^2 - D_h^2}$$

where  $r_t$  is the radius of the outside of the runner (tip radius) and  $r_h$  is the radius of the inside edge of the runner blade (hub radius).

In the spreadsheet, the value of  $v_{w1}r$  is input as a variable for the designer to choose. In some cases – e.g. where a new runner is being designed for an existing casing – this is already fixed by the scroll design, but normally it can be adjusted, thus changing the values of  $v_{w2}$  and  $w_2$ . An initial guess for  $v_{w1}r$  is given in the spreadsheet, based on the Euler Equation and assuming (as a first guess) that  $v_{w2}$  is positive (as seen in Fig.5) and is 10% of  $v_{w1}$ .

<sup>2</sup> Anderson, H H: *Centrifugal Pumps*, Trade and technical Press, Morden, UK, 1980.



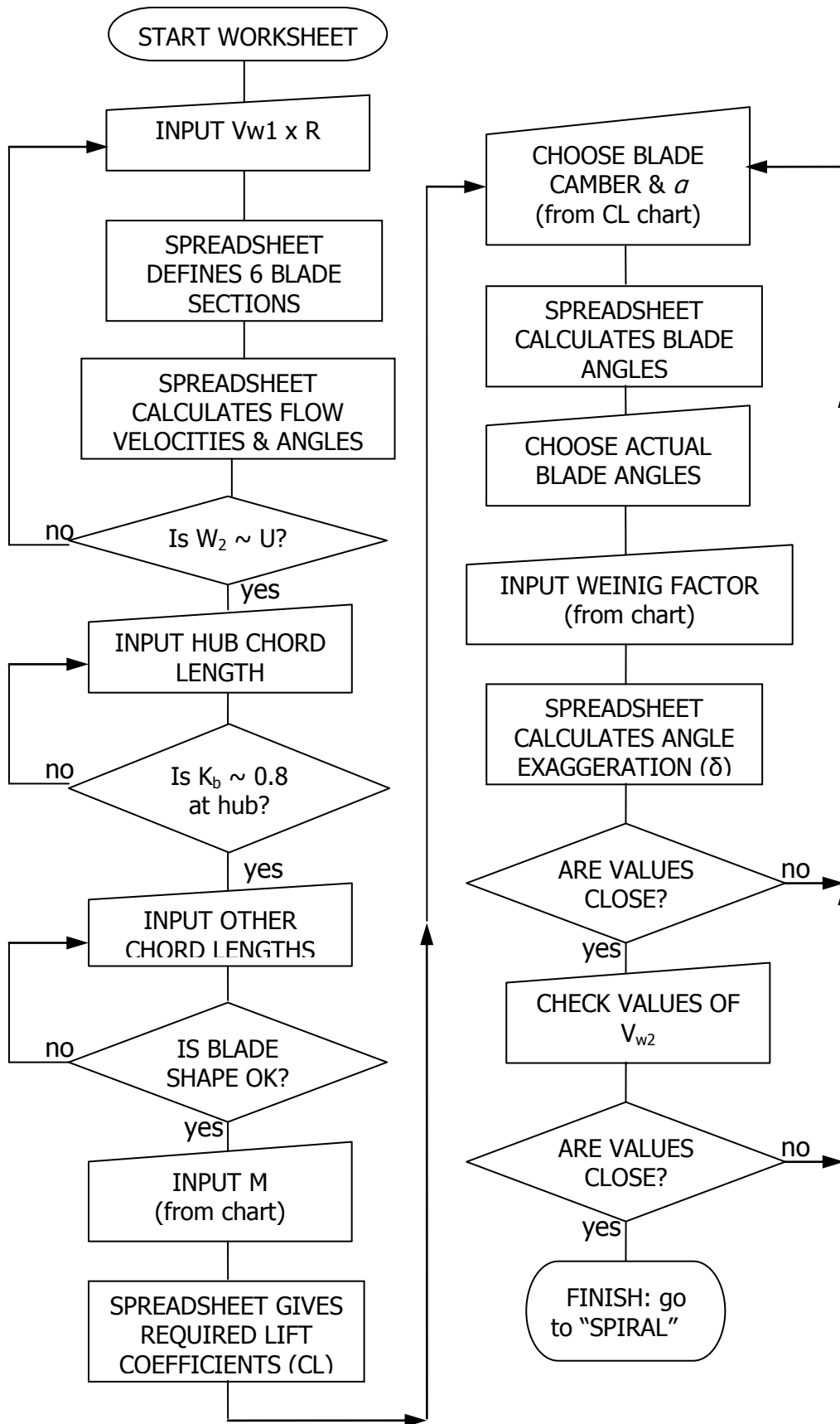

Fig.4. Flowchart for "Runner" worksheet

### 5.1 Exit velocity triangle

For a simple analysis, it is often assumed that there is no whirl velocity at exit,  $v_{w2} = 0$ . However, the angles calculated from this method are different from the actual blade angles in efficient turbines, and a more complicated procedure is recommended. There are several reasons for this:

- the flow does not follow the blades exactly, because there is a relatively large space between each blade;
- the blade of an axial turbine acts as an aerofoil, and operates better with a positive "angle of attack" in order to produce a good torque on the shaft;
- the optimum energy transfer does not necessarily occur when exit whirl velocity is zero.

Nechleba<sup>3</sup>, for example, recommends that the outlet velocity triangle has equal sides ( $w_2 = u$ ) on the basis that this gives highest overall efficiency. For some designs this gives a significant value of  $v_{w2}$ . A value of  $v_{w2}$  somewhere between that for which  $w_2 = u$  and  $v_{w2} = 0$  can then be used. The spreadsheet calculates the flow angles from the velocity triangles and the Euler equation. Note that an adjustment is made to take account of additional losses at the blade hub and tip.

$$v_{w2} = v_{w1} - \frac{g \eta_h H}{u};$$

$$w_1^2 = u^2 - v_{w1}^2 + v_a^2; \quad w_2^2 = u^2 - v_{w2}^2 + v_a^2;$$

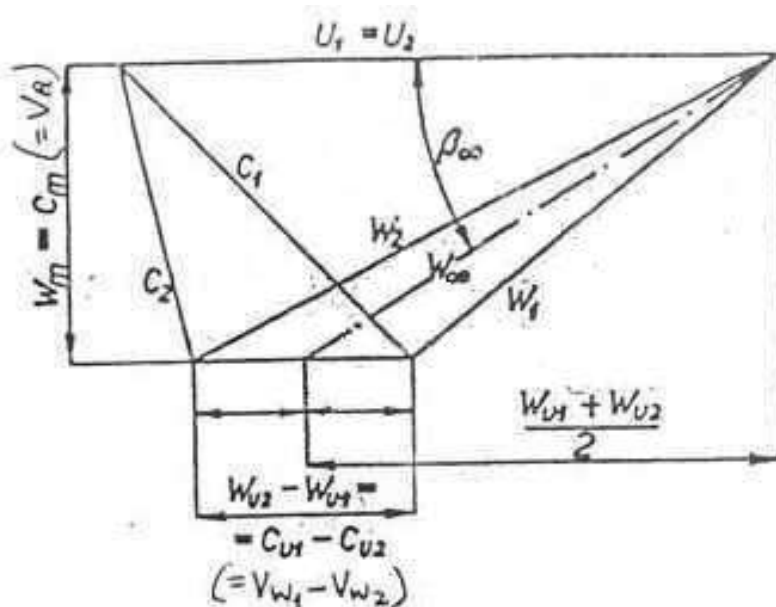

Fig. 5. Diagram of flow velocities, with  $w_2 = u$ .

<sup>3</sup> M. Nechleba, *Hydraulic turbines, Their Design and Equipment*, Artia, Prague (1957).

Note that, since  $u = \omega r$  and  $v_{w1} \propto 1/r$ , (free vortex flow from the scroll casing)  $v_{w2}$  will also be approximately proportional to  $1/r$ , so decreases from hub to tip.

The flow angles are calculated from:

$$\tan \beta_1 = \frac{v_a}{u - v_{w1}}; \tan \beta_2 = \frac{v_a}{u - v_{w2}}; \beta_\infty = \frac{\beta_1 + \beta_2}{2};$$

## 5.2 Runner blade length

Various recommendations are given in the literature for the length of the blade "chord" ( $l$  in the diagram below), normally as a ratio of the blade pitch ( $x$ ), which varies with the radius from hub to tip.

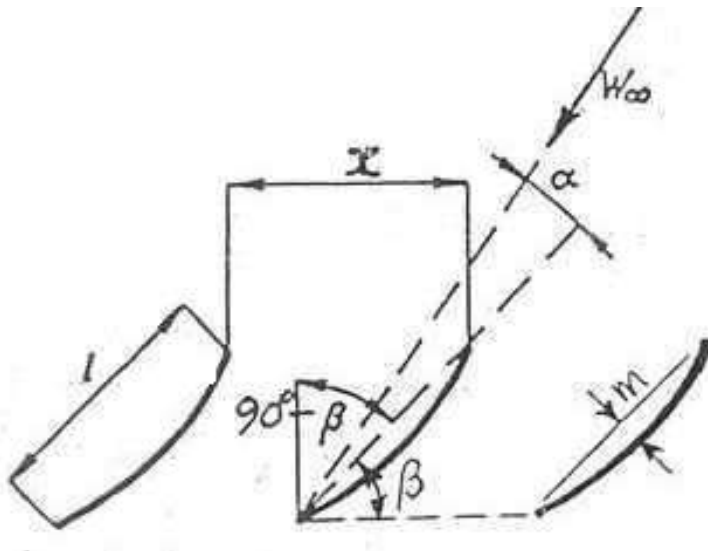

Fig. 6. Definition of angles and blade dimensions

Usually the chord length  $l$  should increase from hub to tip, but the ratio of pitch:chord,  $x/l$ , should also increase from hub to tip. In the spreadsheet, the chart "blade shape" can be used to check that the blade is not a strange shape to manufacture. In the "Coefficients" spreadsheet there is a chart "space chord ratios" that shows a number of recommendations for the values of  $x/l$  varying from hub to tip and as a function of the turbine specific speed. These come from Wu<sup>4</sup>, Ytreøy<sup>5</sup> and Raabe<sup>6</sup>.

From the chord lengths, the "Runner" spreadsheet calculates a factor,  $k_b$ , called "blade loading factor" which is used to find the required lift coefficients.

<sup>4</sup> Wu, Yulin in "Hydraulic Design of Hydraulic Machinery" by H.C. Radha Krishna & A.P. Boldy (Eds.), Ashgate (1997);

<sup>5</sup> AM Ytreøy, "Water turbines", in *Kempe's Engineers Year Book 2000*, Tonbridge : Miller-Freeman, pp1321 – 1344.

<sup>6</sup> J. Raabe; "Hydraulische Maschinen und Anlagen"; VDI Verlag; 2. Edition; Düsseldorf 1989.

It is given in Nechleba's book by the equation:

$$k_b = \frac{2gH\eta_h x/l}{uw_\infty} = MC_L - \frac{C_D}{\tan\beta_\infty} + \frac{C_L^2}{6\pi\tan\beta_\infty}$$

However, the last two terms are found to be insignificant, especially given the lack of accuracy in estimating M and hence  $C_L$ . It is suggested that the value of  $k_b$  at the hub should be approximately 0.8. This is known as the Zweifel criterion, which is ironic, since Zweifel, in German, means "doubt" and there is some doubt as to the applicability of this criterion for the case of water turbines, since it was originally developed for compressible fluids.

The value of M depends on the value of  $\beta_\infty$  and  $x/l$ , according to the chart below. The "Runner" spreadsheet now calculates the required values of lift coefficient,  $C_L$ , for each of the blade sections.

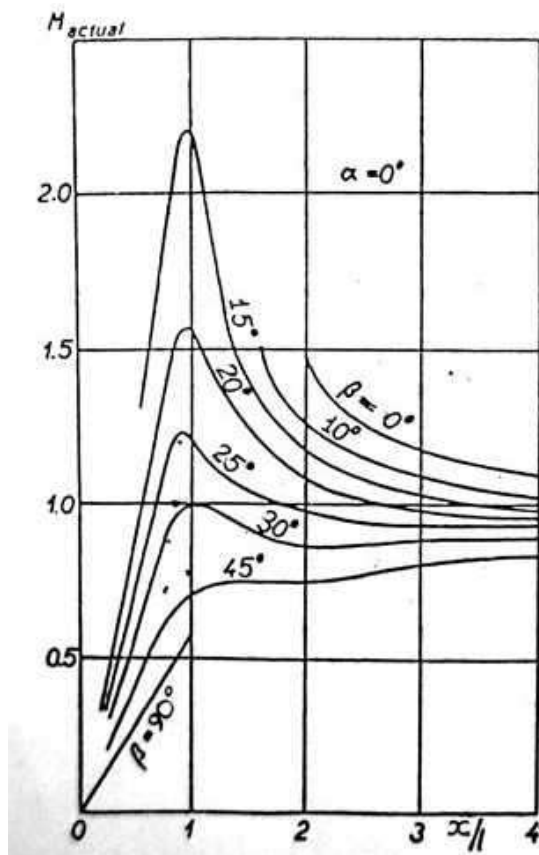

Fig. 7. Factor to modify Lift Coefficients due to multiple blades (adapted from Nechleba). Although it is strictly for  $\sigma = 0$ , it is applicable to other values, as long as the blades are relatively thin.

### 5.3 Runner blade shape

The blade shape has three variables: the angle of attack,  $\sigma$ , the thickness,  $t$ , the camber,  $m$ , in this case given as a percentage of chord length,  $l$ . In the spreadsheet "Coefficients" there is a chart of lift coefficients for thin, constant thickness blades. This is based on values from fan blade tests<sup>7</sup>, but the

<sup>7</sup> R.A. Wallis, "Axial flow fans: design and practice", G. Newnes, London, 1961.

Reynolds number is similar to that in water turbines, so the results should be applicable. Normally, the angle of attack and the blade camber will both increase from blade tip to blade hub. The values should be chosen to give the values of lift coefficient in the spreadsheet line  $CL$ .

The next rows on the "Runner" spreadsheet lead to the calculation of the actual blade setting angle (*beta calculated*), by subtracting the angle of attack. It also calculates the axial length of the blade ( $L_{hub}$ ). This is particularly important at the hub section, because it determines the minimum axial length of the runner hub. The angles can be rounded off or adjusted and are input manually, after which the spreadsheet calculates the solidity – the amount of each circumferential section that is covered by blade when looking parallel to the turbine axis. In case these values look impractical, it may be necessary to go back and adjust the blade chord length or even the number of blades.

The next two rows in the spreadsheet calculate the arc radius and deflection angle, based on a circular arc. There is now an additional check that can be carried out to complete the design. Again, as used by fan designers (who are most used to applying constant thickness curved blades), there is a relationship between the flow deflection angle ( $\beta_1 - \beta_2$ ) and the blade deflection angle. The flow is deviated less than the blade deflection, as mentioned in section 5.1, and there is an "angle exaggeration factor",  $\delta$ , that can be used to find the ratio of flow deflection to blade deflection, based on the work of Weinig as quoted by Bohl and Bommers<sup>8</sup>. The chart in spreadsheet "Coefficients" gives the value of  $\delta$  as a function of  $\beta_\infty$  and  $x/l$ .

If the actual value of "theta ratio" is greater than the value extracted from the chart, then the  $CL$  chart should be used again. The angle of attack should be reduced and the camber increased to give the same required value of lift coefficient, but with a greater value of blade deflection.

As a final check, the spreadsheet re-calculates the exit flow angle, based on the angle exaggeration and then re-calculates the exit whirl velocity,  $v_{w2}$ . The value of exit whirl should agree fairly closely with the values highlighted in blue earlier in the spreadsheet.

## 6. Casing Design Guide

This guide and the current "Spiral" worksheet calculate the dimensions for a spiral with a tapering rectangular cross-section. There are three parameters that have to be input at the top of the worksheet: firstly, the radius at the inner edge of the spiral (where most larger turbines have guide vanes –

---

<sup>8</sup> Leonhard Bommers, Jürgen Fricke, Reinhard Grundmann, "Ventilatoren", 2<sup>nd</sup>. Ed. Vulkan-Verlag GmbH, 2003.

hence  $R_g$ ). This must be larger than the runner radius in order to allow for a chamfer or radius at the turn into the runner tube section.

A radius (as shown on the right hand side in Fig. 8) is preferable to a chamfer, but may be more difficult to manufacture. In either case, allow an increase of at least 5% of the runner diameter. The second parameter is the height of the inlet section at the inner radius of the spiral, before the flow changes direction into the runner,  $b_0$ . Finally, the cross-section of the spiral inlet,  $B$  is input by the designer.

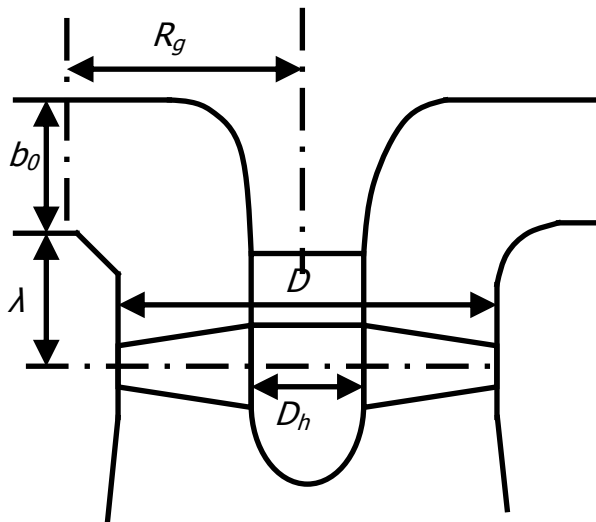

Fig. 8. Dimensions of Runner Inlet

It is recommended that  $0.35 \leq b_0/D \leq 0.5$ , increasing with increasing specific speed. The value of  $B$  is then adjusted so that the two values of "Q/VwRw" are as close as possible, which is when:

$$\frac{Q}{v_w R} = B \log_e \left( 1 + \frac{B}{R_g} \right)$$

The height of the spiral is also calculated and a chart shows the how the height decreases with spiral angle. This can be used to check that there is not a large discontinuity towards the centre of the spiral. The value of the runner setting height,  $\lambda$ , must also be decided. Nechleba and Bohl both recommend about  $D/4$ .

## 7. Draft Tube guidelines

A draft tube recovers some of the kinetic energy from the runner outlet and should reduce losses due to non-uniform flow into the tailrace. A simple conical draft tube is normally acceptable, but in some cases a  $90^\circ$  bend is required to (e.g. for a horizontal axis turbine). Any bend must be designed with parallel or increasing diameter, so that it does not restrict the outflow from the turbine. A divergence angle for draft tube of between  $8^\circ$  and  $12^\circ$  is recommended, i.e. for a symmetrical vertical cone, the sides should be  $4^\circ$  to

6° from the vertical. The draft tube length should be between 4 and 10 times the diameter of the runner, giving an outlet diameter of 1.8 to 2.5 times the runner diameter. Note that the axial velocity through the draft tube will be reduced in proportion to the area – i.e. by a factor of between approximately 3 and 6.

### **Acknowledgements**

This work was made possible by a grant awarded by the Leverhulme Trust while the authors were employed at Nottingham Trent University. The final publication has been supported by the University of Nottingham, which also hosts the website "picohydro.org.uk".

The authors acknowledge the useful contributions of Marko Kogovšek, an engineer from Slovenia, who was the first to try out the guide and spreadsheets, and Bryan Ho-Yan from the University of Guelph, Canada, who also made suggestions for improvements.